

PIPE-FLO Professional from Engineered Software is widely used to design and simulate the operation of fluid piping systems. With the release of the PIPE-FLO Software Development Kit (SDK), system integrators and application developers can tap into the speed and power of PIPE-FLO when developing their own custom applications.

Overview

The PIPE-FLO program from Engineered Software is widely used to design and simulate the operation of fluid piping systems. It calculates the flow rates and pressures, providing a clear picture of the total piping system.

The new PIPE-FLO SDK (Software Development Kit) provides application developers unprecedented control over all aspects of the PIPE-FLO Professional program.

The idea is straightforward: PIPE-FLO has a wealth of information about the piping system, needed to simulate the operation of the system. If you are developing an application that can take advantage of PIPE-FLO's capability, our PIPE-FLO SDK will fulfill your needs while cutting months off your development schedule. By having your application talk directly to PIPE-FLO, you can complete your custom application faster, while taking advantage of our stable program and large customer base.

Interfacing with PIPE-FLO

Using the SDK, your application can obtain information (either design data or calculated results) from the piping system model by way of the PIPE-FLO program. In addition, your application can send information to PIPE-FLO to modify the piping system model, run calculations, and return the results to your application.

Your application sends requests to the communication module supplied with the PIPE-FLO SDK. The communication module processes and forwards your request to the PIPE-FLO program (retrieving design data, making changes to the design, performing the calculations, returning the calculated results). PIPE-FLO processes the request, and then returns the information to the calling application by way of the communication module. See figure 1 below. The application can be written in Visual Basic, Visual C++ or any development environment capable of communicating with Dynamic Link Libraries (DLLs).

Developing a Application using the PIPE-FLO SDK

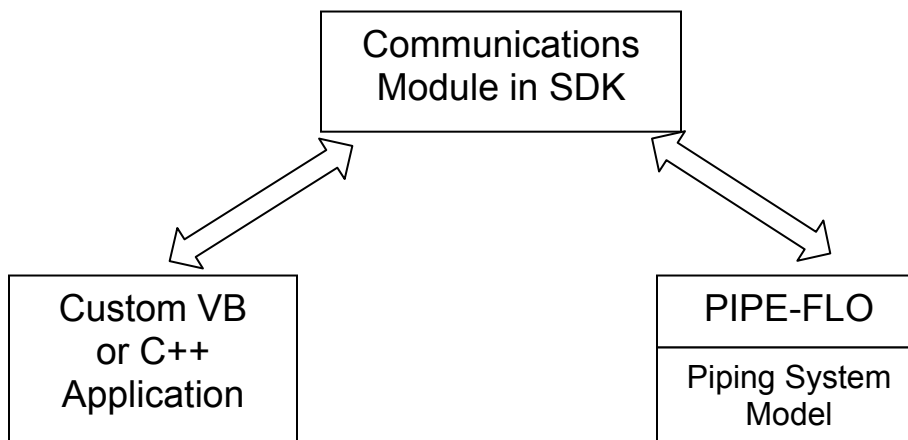

Figure 1 – The Software Development Kit allows PIPE-FLO to communicate directly with applications written in Visual Basic or Visual C++. The custom application can direct PIPE-FLO to read design data, calculated results, and change information in the piping system model.

Custom applications written using the PIPE-FLO SDK operate with our standard PIPE-FLO Professional program. Alternatively, you can develop your application so PIPE-FLO runs in the background; here you control the user interface and just use PIPE-FLO's calculation capability.

Applications written using the PIPE-FLO SDK fall into three general categories:

- Adding functionality to PIPE-FLO
- Using PIPE-FLO as a back-end component to your application
- Integrating PIPE-FLO with multiple programs

The following examples demonstrate these three categories.

Adding Functionality to PIPE-FLO

In this example, a programmer at an engineering firm is developing a Piping System Estimator application to estimate the cost of building a piping system. Since the engineering firm is using PIPE-FLO to design the piping system, the application uses the SDK to gain access to the data contained in the piping system model.

Using the PIPE-FLO program, designers and engineers size pipelines, perform the hydraulic network analysis, select equipment, and simulate the system under any operating condition. The design details included in the project model provide a wealth of information.

The Piping System Estimator application, developed with the PIPE-FLO SDK, extracts information for each pipeline (pipe material, schedule, nominal size, length, diameter, along with the types and numbers of valves & fittings) from the piping system model. The Piping System Estimator looks up the price for each item found in the piping system model and returns cost data for each pipeline. The application also assembles a bill of materials to be included in the specification documents for the pipe, fittings, valves, control valves, pumps, and components. See figure 2.

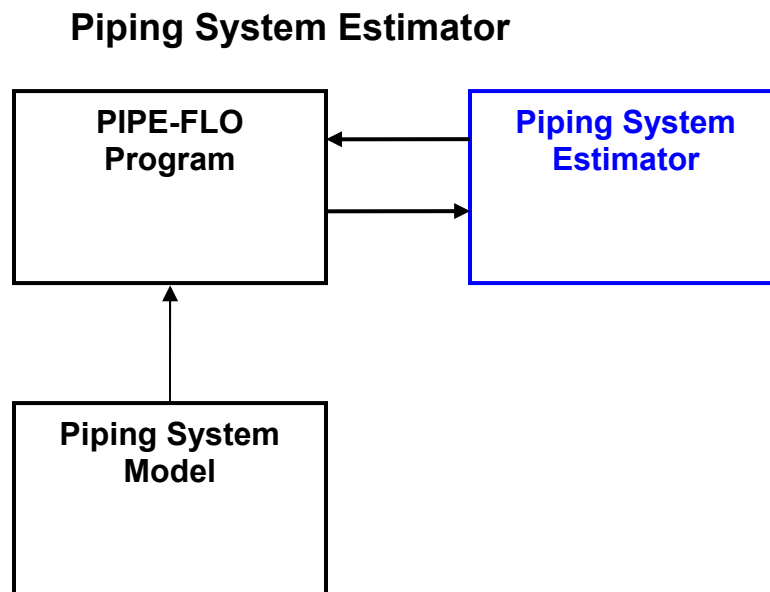

Figure 2 - The Piping System Estimator requests the pipeline details from the PIPE-FLO program. PIPE-FLO returns the information for each pipeline in the system model. If the piping system model changes the Piping System Estimator provides a new estimate based on the most recent design changes.

By taking advantage of the design information already available in the PIPE-FLO piping system model, the Piping System Estimator can turn a powerful engineering tool into a powerful piping project design and management system.

Using PIPE-FLO as a Back-End Component

In this example, PIPE-FLO provides calculation services to a custom application, in which the user does not interact with the PIPE-FLO program interface.

A Plant Monitoring Application can alert plant operators when equipment is running outside of the manufacturer suggested operating ranges, indicating the potential for impending failure.

Monitoring the plant's installed instrumentation provides an indication of the system's health, but one quickly becomes lost in a sea of data. Waiting until a pump's discharge pressure drops below a critical level may be too late, because what looks like a normal discharge pressure under some operating circumstances may mask the early indication of a problem. This is where an accurate model of the piping system is invaluable.

The Plant Monitoring Application pulls system-operating information for the plant's Distributed Control System (DCS) system and sends it to the PIPE-FLO program (pumps running, valve positions, tank levels, control valve set points, etc.) PIPE-FLO calculates how the entire system should be operating, based on the system current operating condition, and then sends the calculated results to the Plant Monitoring Application. PIPE-FLO's calculated results are compared to the actual plant operating data. The Plant Monitoring Application warns the operators when a specific piece of equipment falls outside a pre-defined range. See figure 3.

Plant Monitoring Application

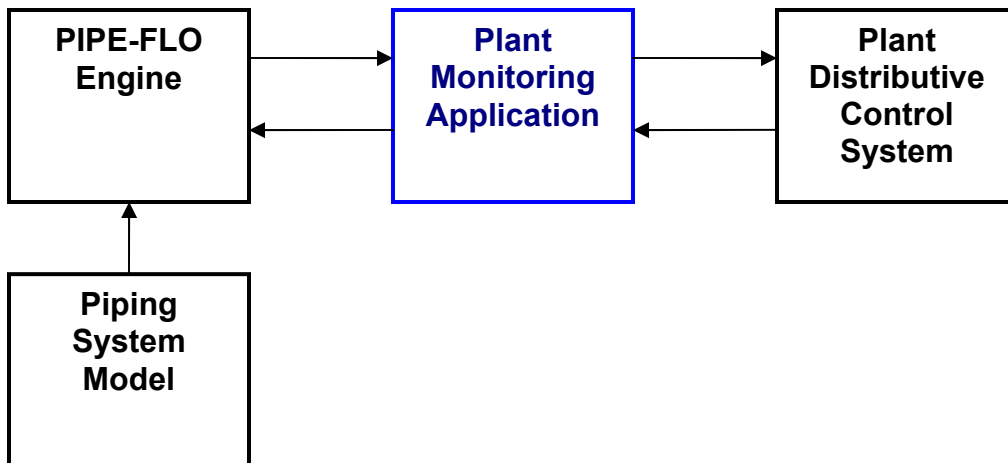

Figure 3 - The Plant Monitoring Application pulls information from the plant's DCS system and sends information to PIPE-FLO. PIPE-FLO calculates how the system should operate. The Plant Monitoring Application compares the calculated result with the actual plant operating data.

The Plant Monitoring Application takes advantage of both the plant's DCS system and a PIPE-FLO model. The Plant Monitoring Application calls two continually running programs, processes the information, compares the results, and notifies the operators. By using the PIPE-FLO SDK, the application developer can employ the fast and highly accurate PIPE-FLO calculations without the prohibitive cost of writing the code to perform the calculations. PIPE-FLO becomes a silent partner, performing the system calculations and letting the application developers concentrate on their mission critical application.

Integrating Multiple Programs

In this example, PIPE-FLO becomes a user-friendly front end providing seamless integration with two other applications used extensively by plant maintenance personnel.

A Plant Maintenance & Document application interfaces PIPE-FLO to the plant's existing asset management and document management programs. The asset management program provides the maintenance department with the maintenance history of the plant's equipment along with the ability to schedule maintenance operation for selected equipment. The document management program provides personnel with access to drawings, manuals, and operating procedures needed to repair and maintain the equipment.

PIPE-FLO is an excellent troubleshooting tool for operating plants. An operator uses PIPE-FLO to compare the operation of the physical plant with the way the plant was designed to operate. This helps the operator to identify problem areas within the piping system, which is the first step in fixing the problem. The second step is to schedule and record all plant maintenance activities using the existing asset management program.

Using the Plant Maintenance & Document Application, the operator highlights an item on the FLO-Sheet, and then launches the asset management program allowing the operator to see the maintenance history and schedule the repair work.

The next step involves reviewing the maintenance procedures, manufacturer's maintenance instructions, and design drawings. Once again, the user highlights the object on the FLO-Sheet and launches the plant's Document Management program, displaying a list of documents for the selected item. This allows the mechanic to select and view the necessary documents. See figure 4.

Plant Maintenance & Document Application

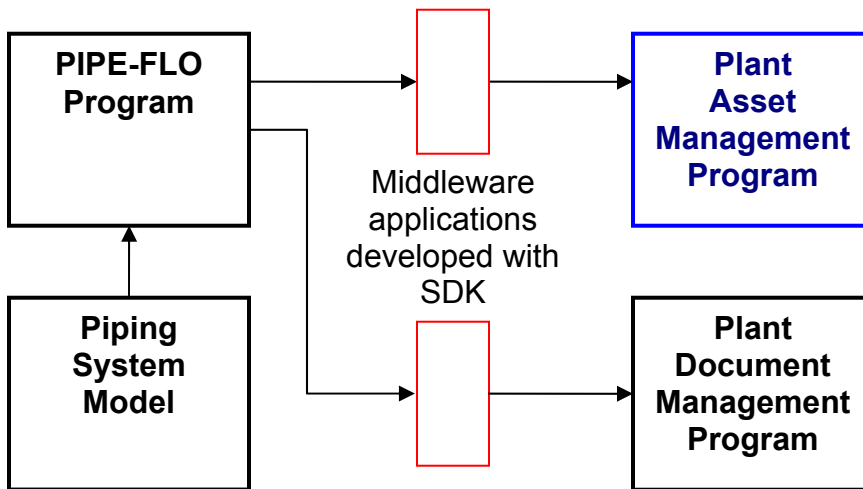

Figure 4 - The Plant Maintenance & Document application provides a seamless interface between PIPE-FLO program and the plants existing asset management, and document management programs. PIPE-FLO then becomes an easy to use front end to these mission critical applications.

The Plant Maintenance & Document application consists of the PIPE-FLO program, asset management program, and document management program, along with a middleware application to tie the three programs into an integrated system. The application programmer develops the middleware application using the PIPE-FLO SDK along with the Software Development Kit for the other applications. The middleware application provides the communication between the three programs, eliminating the need for the mechanic to start three separate programs to get the information required to make a repair.

Information Available from the Piping System Model

The following is a list of variables in the piping system model accessible using the PIPE-FLO SDK.

Units			
Flow rate units Pipe diameter units Length units	Velocity units Elevation units	Density units Temperature units	Pressure units dP Units
Objects			
Object name Object tag status Specification name*	Fluid zone name * Pipe Nominal size * Pipe length*	Node elevation Inlet elevation Outlet elevation	* pipelines only
Pipelines			
Specification ID Pipe material Pipe schedule	Fluid zone ID Fluid name Fluid temperature	Fluid zone pressure Pipe inside diameter K for valves & fittings	Downstream node Upstream node
Lineup			
Pump - set & type Controls – set & type	Demand – set & type	Tank – press & level	Pipe – status (closed, one way, both)
Calculation			
Status (error/warning) Flow rate Sum flow into a tank Pressure	Hydraulic grade Temperature Velocity Pipe dp	Pipe dP per 100 Pipe head loss Head loss per 100 Reynolds number	Pump total head Pump NPSHa dP across object

Table 1- The following information found in the piping system model can be read or modified using the PIPE-FLO SDK.

Conclusion

Using the PIPE-FLO Software Development Kit, a programmer or system integrator can develop far-reaching applications employing the power of the PIPE-FLO program and the accuracy of the piping system model.

For more information on the PIPE-FLO Software Development Kit and its application, please contact Engineered Software at 1 (800) 786-8545 and ask for the SDK Details.